

HCM4

Thermal Energy Calculating Meter Systems For 'The Digital Age'

HCM4006 - Thermal Energy Calculating Meter - 230 volts

M-Bus With Pulsed Output **M-Bus**

Calculates The Energy Used In Heating or Cooling Systems
KWh & Monetary Read Outs (£ \$ E)
Digital High Accuracy Sensors
Strap On Pockets
'On Site' Programming Facility
Manufactured to ISOEN 1434 Parts 1 to 6



M Bus Set Up
Primary Addressing
Baud Rate 300
Meter ID – On Front Label
M Bus - Status 0 = Normal
M Bus – Status 1 = Fault



Order Code(s)

hcm4000 – mbus (Standard Version) With Monetary Value & Re Settable
hcm4000 – mbus hp As above but High Precision Version

HCM4

Thermal Energy Calculating Meter Systems For 'The Digital Age'

Installation Instructions

The HCM4 consists of 3 component parts

- 1 – The HCM4 Energy Calculating Meter
- 2 – A Set (of two) Digital High Accuracy Digital DHAS sensors
- 3 – A Set (of two) 'Strap On' Pockets – The temperature sensor bulbs can be strapped directly onto the pipe work .

Mounting

The HCM4 is designed for wall mounting, a screw case hanging position is located at the top centre of the case with two wall fixing positions located under the terminal cover

Wiring

Wiring block list -- terminals are marked on the pcb –
Remove Meter front cover to expose wiring block

Wiring Terminal List

1 = Power In (+) -Either Mains 230v (110v USA) or 24v

2 = Power In (-) - Either Mains 230v (110v USA) or 24v

3 = Sensor Hot -- Brown

4 = Sensor Hot -- Green

5 = Sensor Hot -- Blue

6 = Flow Meter 1 (+) (The red led on front of case flashes when it receives a pulse from the flow meter)

7 = Flow Meter 1 (-)

8 = Pulsed Output 1 (+)

9 = Pulsed Output 1 (-)

10 = Analog Output (4 -20 mA) 1 Active (where fitted)

11 = Analog Output (4 - 20 mA) 2 (where fitted)

12 = Analog Output (4 - 20 mA Passive (where fitted)

13 = CAT Terminal (+) –Building Alarm Terminal (where fitted) www.hcm4.com/cat.htm

14 = CAT Terminal (-) – Building Alarm Terminal (where fitted) www.hcm4.com/cat.htm

15 = Pulsed Output 2 (+) -- (where fitted)

16 = Pulsed Output 2 (-) -- (where fitted)

17 = Flow Meter 2 (+) -- (where fitted)

18 = Flow Meter 2 (-) -- (where fitted)

19 = Sensor Cold -- Brown

20 = Sensor Cold – Green

21 = Sensor Cold -- Blue



Installation Tip
Fit sensors and wire in
before powering up

HCM4

Thermal Energy
Calculating Meter Systems For
'The Digital Age'

HCM4006 – Wiring (M Bus)

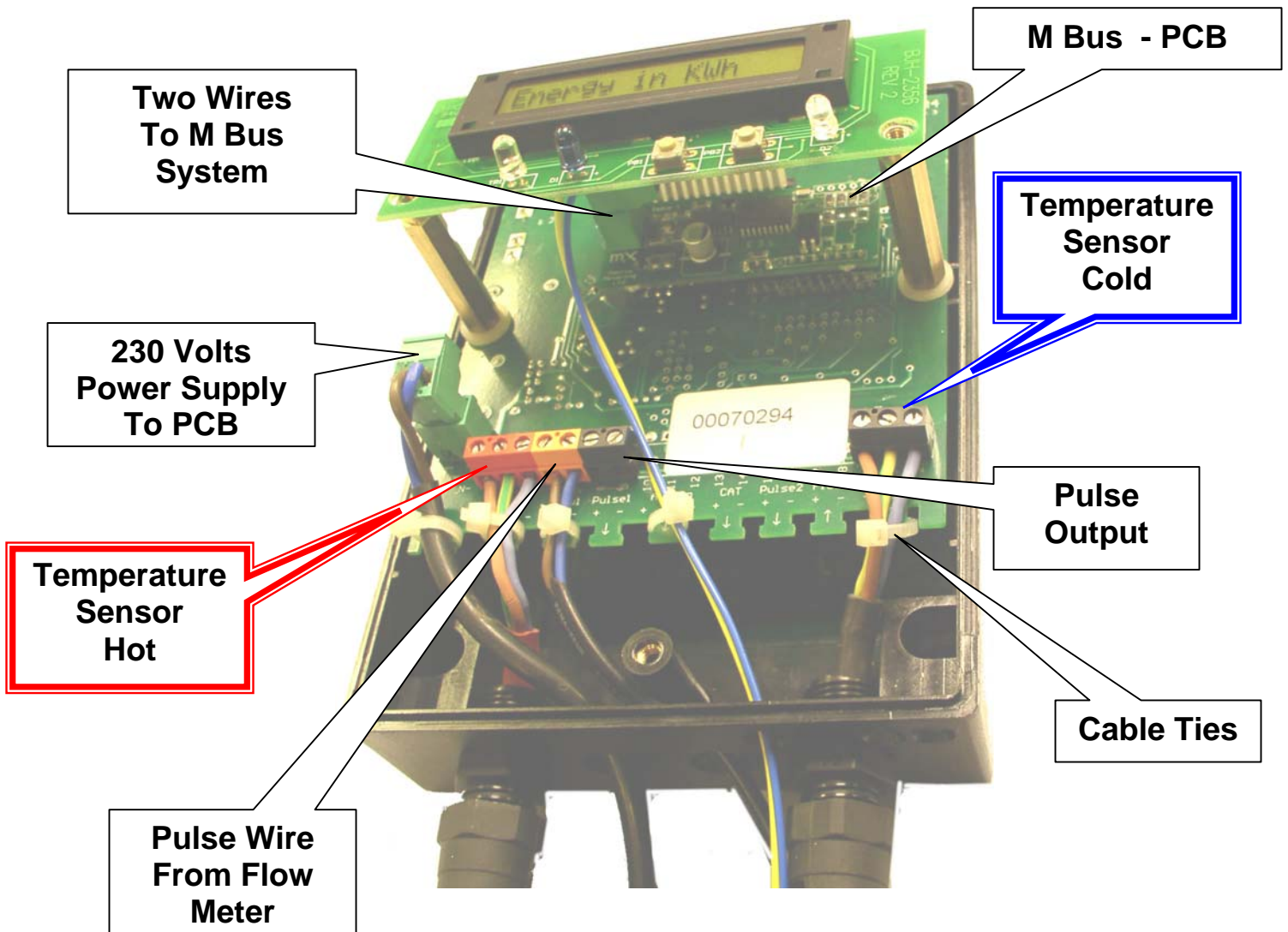

Thermal Energy Calculating Meter Systems For 'The Digital Age'

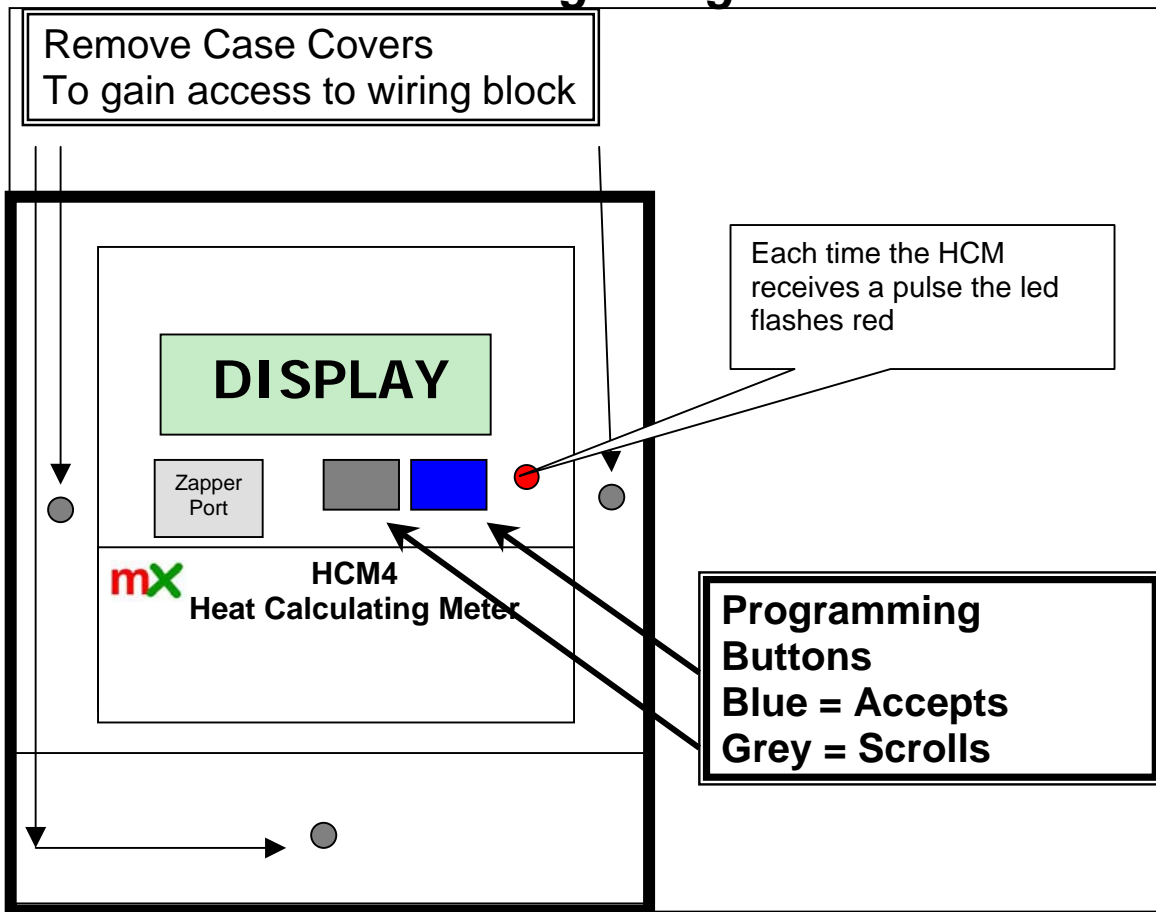

Installation

Remove HCM4 cover and install all wiring leaving the **connection of either mains supply 230v or 24v**

Wiring standards must conform to IEE regulations

It is recommended to use shielded cable manufactured to BS4360 Class 5 or VDE0295 Class 5

DHAS Sensors (Digital High Accuracy Sensors)

Are highly accurate, temperature thermometers, they are calibrated to an accuracy of 1.0% and a calibration certificate is included with each sensor set.

DHAS are highly efficient, and

The **Red Coloured Sensor**, should always be located in the hottest pipe

Heating Circuit = Flow Chilled Circuit = Return

The **Black Coloured Sensor**, should always be located in the coolest pipe

Heating Circuit = Return Chilled Circuit = Flow



Standard DHAS Sensors can be cut /trimmed without losing accuracy and added to up to a distance of 10 metres. Above that distance LD version sensors should be used these have a maximum range of 200 metres

HCM4

Thermal Energy Calculating Meter Systems For 'The Digital Age'

Pipework Recommendation

It is strongly recommended that the pipe work is correctly protected with the following valves :- Gate Valves (x2) Strainer (x1)

Should these not be fitted, the company takes the option to invalidate any guarantee(s)

Heat Calculating Meter

HCM4

'How it all fits'

Pipe Work and Valve Layout
Hot or Chilled Water Circuit

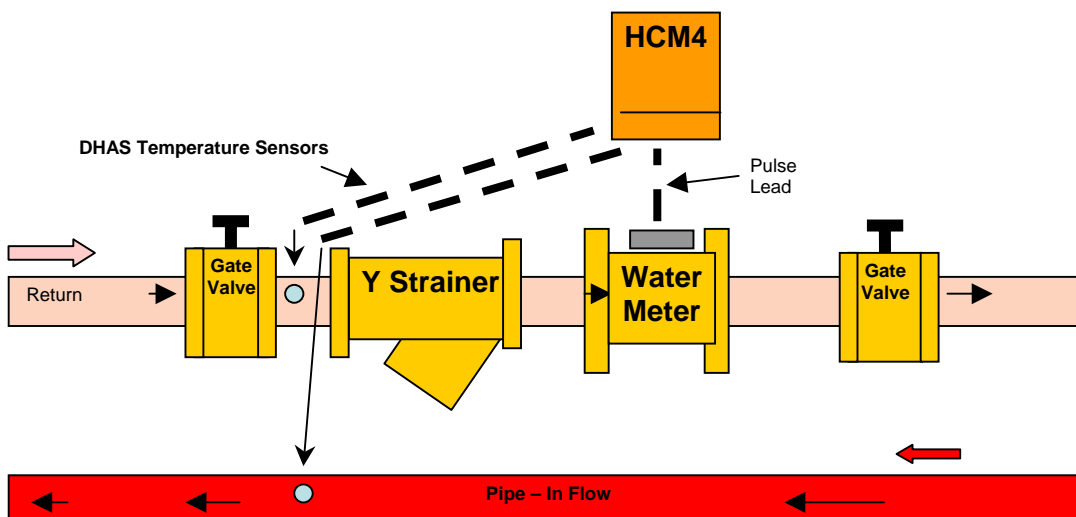

DHAS Sensors (Digital High Accuracy Sensors)

DHAS Sensors are highly accurate, calibrated temperature sensors, they are designed to fit into pockets which onwardly fit into the pipe work. The sensors have individual serial numbers located on the sealing tags, and a calibration certificate is supplied with each set.

Unlike other similar products DHAS sensors are both flexible and reliable. And are extremely installer friendly

A – They do not have to be a matched pair

B – They can be cut in length without effecting calibration

C – They can be added too. (to a maximum of 10 metres) – And up to 200 metres with the LD Version www.hcm4.com/LD

Error Codes

- Act as a 'Que' in the software to inform of potential problems. When an 'ERROR' occurs the HCM4's buzzer operates.

ERROR 1 No sensors connected or shorted to 5volts

ERROR 2 Data shorted to 0 volts

ERROR 3 Data transmission error

ERROR 4 Only 1 sensor connected

ERROR 5 Not a pair (either 2 hot or two cold connected)

FREEZING Temperature in pipes or below 1c NEGATIVE DELTA T The sensors are likely too be the wrong way round

HCM4

Thermal Energy Calculating Meter Systems For 'The Digital Age'

Programming Heat Calculator At Boot up - Sequence

Matrix Metering
HCM4006 Version No 2.7

Boot Up –

Is split into 4 sections each section scroll (Left/Grey Button) and Accept with (Right/Blue Button)



Installation Tip
Buttons
Left/Grey = Scroll
Right /Blue = Accept

1st Screen Set (Setting of Energy Unit)

Energy in KW/KWh

Energy in MW/MWh

Total Billing Counter either Kilowatt hours (standard) or Megawatt Hours (commercial)

2nd Screen Set (Billing Preference) 2/a

Resetable Energy

Billing in KWh's

Resetable Money

Billing in Monetary Value

Screen 2/b

Cost 000.p KWh

If this option chosen

See Page 8
For full
explanation



3rd Screen Set (What type of system is it)

Heating System

Cooling System

Heating/Central Heating/Hot Water

Cooling/Chilled/Air Conditioning

4th Screen Set (Where is the flow meter located)

Meter in Return

Meter in Flow

Where is the flow/water meter located – Return pipe (standard) or Flow pipe

HCM4

Thermal Energy Calculating Meter Systems For 'The Digital Age'

5th Screen (Pulse value from Water Meter)

F1 0001 L/pulse

F1 0100 L/pulse

Pulse value selectable 1,10,100,1000 litres per pulse
Example F10 = 10 litres of water per pulse
(The pulse value is always located on the meter)

END OF PROGRAMMING THE HCM4 NOW AUTOMATICALLY SCROLLS THROUGH THE SETTINGS

6th Screen Set



Reject Settings

Accept Settings

THIS STAGE IS VERY IMPORTANT

If during the auto scroll you are unsure of the setting – press Reject Settings and start again
Should you be sure the settings are correct - press Accept Setting



7th Screen

Hold to Save ..

You will need to hold the Blue/Right button down firmly for 10secs – the buzzer will sound continuously

Last screen

Saved

At this point all the settings are saved

Operational Data

Default Screen

See Page 8
For full explanation

RM £ 050.25

RE 45697.1 KWh

Resettable Money

Resettable Energy KWh/MWh



HCM4

Thermal Energy Calculating Meter Systems For *'The Digital Age'*

Total

TE	0000000.0 KWh
----	---------------

Total consumption in KWh's (or MWh'S) Nine digits + One 1/10 (NOT reset table)

**Instantaneous
Energy**

IE	23 KW
----	-------

The amount of energy being consumed in the circuit NOW

**Temperature
Flow**

tf	78.8C
----	-------

Temperature in the flow pipe

**Temperature
Return**

tr	78.8C
----	-------

Temperature in the return pipe

Flow

F1	354.87 m3/h
----	-------------

Total flow in metres cubed per hour 1 m3h = 3.6 litres

To Change Settings

Once passed screen set no 7 – the only way to access the settings is with a Zapper Unit
Reference www.hcm4.com/zapper.htm

Outward Pulse Data – Open Collector

Maximum Operating Voltage 45vdc
Clamp circuit interjection 65vdc
500watt Power Dissipation Limit - Max Current 10amp
Reverse Connection Protection 6vdc
Pulse Width 50 ms
DC Forward Current 0.6v
Rise And Fall Max 18 micro Secs
Isolation Résistance 5 x 10/10 ohms
Isolation Voltage 5 kV
Collector Remitter Saturation Voltage 0.4volts
Operating temperature range -55c to 130c

HCM4

Thermal Energy Calculating Meter Systems For 'The Digital Age'

Outward Pulse Value

10 pulses per KWh (if set for KWh's)

OR

10 pulses per MWh (if set for MWh's)



EXPLANATIONS & FAQ's

(Ref 2nd Screen Setting) Reset able Energy (A) or Monetary Value (B)

This offers the option of either having the default screen showing as :-

A Energy -- Shown as KWh (standard applications) or MWh (Commercial Applications)

B Monetary Value -- Shows the value as real money !!!



Q1 -- Can I reset the screens

A1 -- Yes with a zapper unit

Q2 -- Do I lose all the data at reset

A2 -- No the system integrity is kept, the 2nd screen in operation retains the total usage since start and is not resettable

Q3 -- What security of settings are there

A3 -- Once the settings have been saved (9th Screen) they cannot be tampered with

Q4 -- How can I change the settings and monetary values

A4 -- Security is important for this reason we have developed a zapper unit

The zapper www.hcm4.com/zapper.htm unit will open the software for settings and monetary value resetting. The company registers each zapper unit sold

Q5 -- What is shown on the screen when in operation

A5 -- The current total which can be reset – either KWh's or Monetary value

Q6 – I am trying to set up a HCM and I keep getting 'POWER FAILURE' on the display .

A6 -- The sensors are incorrectly wired – re check the wiring



Guarantee

All products are guaranteed on a return to base basis only, for a period of 12 months from dispatch date.

No compensation can be offered, relating to consequential loss.

Where HCM4 Calculators are installed, not using Meters UK water/flow meters

This could alter the known operational criteria, and effect the product integrity. The company reserve the rights to refuse claims where deemed correct.

This product is sold subject to the company Despatch, Guarantee & Returns Policy only
www.meters.co.uk/policy.htm

HCM4

Thermal Energy Calculating Meter Systems For 'The Digital Age'

Other HCM4 versions available

CAT Terminals (Calculator Alarm Terminal)



Offers the option of providing a error alarm to a Building Management System

How it works -- The BMS despatches a voltage (max 30 volts) to CAT Terminal 1 (wiring terminal 13)

In the event of an error occurring a voltage would be returned to the BMS on CAT Terminal 2 (wiring terminal 14)

In operation CAT Terminal 2 would have zero volts – In error

mode CAT Terminal 2 would have a voltage

High Precision

Where high accuracy is required the HP version uses higher quality materials to be able to be calibrated to 0.02% accuracy

LD (Long Distance) Temperature Sensors

Temperature sensors that can measure accurately for distances from 10 metres up to 200 metres

HCM4 – Enclosures



Order Code VW302517

Size H 300x W 250x D 170 – External

H 270x W 240x D 130 – Internal

Plexiglass Viewing Window to BS EN 100

- ✓ High Quality
- ✓ Heavy Duty
- ✓ Suitable for both Internal & External Mounting
- ✓ High Impact Resistant
- ✓ IP67 Rated

meters uk Ltd

Whitegate, White Lund Trading Estate, Lancaster,
Lancashire, UK, LA3 3BT Tel 01524 555929 Fax 01524 847009

e mail sales@meters.co.uk website www.meters.co.uk



Certificate No. 2009

www.hcm4.com